

Electrical Force Transducer – Model 304



- Capacities: 1kN bis 50kN
- For compression and tension
- Stainless steel
- Very small dimensions
- Sensitivity: 1mV/V
- High accuracy
- For dynamic applications
- Optional: TEDS Module available ¹⁾

The electrical force transducers of the model series 304 are preferentially used where installation space is scarce and other possibilities for larger devices are not available. If the miniature force transducers that are made of stainless steel have been adapted accurately they convince with a long product life as well as precise measurements. On demand you receive the model 304 also with a TEDS module.

Model 304				
>> Technical data according to VDI / VDE directive 2638		Symbol	Unit	Standard
Zero signal when removed		S_0	mV/V	0,01
Rated characteristic value		C_{nom}	mV/V	1
Relative error of characteristic value		d_c	%	$\leq \pm 0,3$
Relative linearity error		d_{lin}	%	$\leq \pm 0,1$
Relative repeatability error in unchanged mounting position		b_{rg}	%	$\leq \pm 0,04$
Combined error		F_{comb}	%	$\leq \pm 0,5$
Reference temperature		T_{ref}	°C	21
Rated temperature range		$B_{T, nom}$	°C	0...+50
Operating temperature range		$B_{T, G}$	°C	-15...+60
Storage temperature range		$B_{T, S}$	°C	-20...+70
Relative creep after 30 min		$K_{0,5}$	%	$\leq \pm 0,08$
Relative creep after 8 h		K_8	%	$\leq \pm 0,024$
Temperature effect on characteristic value per 10K		TK_C	%	$\leq \pm 0,1$
Temperature effect on zero signal per 10K		TK_0	%	$\leq \pm 0,1$
Input resistance		R_e	Ω	375 ± 25
Output resistance		R_a	Ω	350 ± 2
Insulation resistance		R_{is}	G Ω	> 2
Max. excitation voltage		U	V	12
Rated range of excitation voltage		$B_{U, nom}$	V	5...10
Limit force		F_L	%	≤ 150
Breaking force		F_B	%	≥ 300
Max. permissible dynamic load ²⁾		L_{dy}	%	≤ 50
Degree of protection acc. to DIN 60529				IP67

¹⁾ TEDS = Transducer Electronic Data Sheet acc. to IEEE 1451.4

²⁾ Oscillation amplitude acc. to DIN 50100

Electrical Force Transducers – Model 304

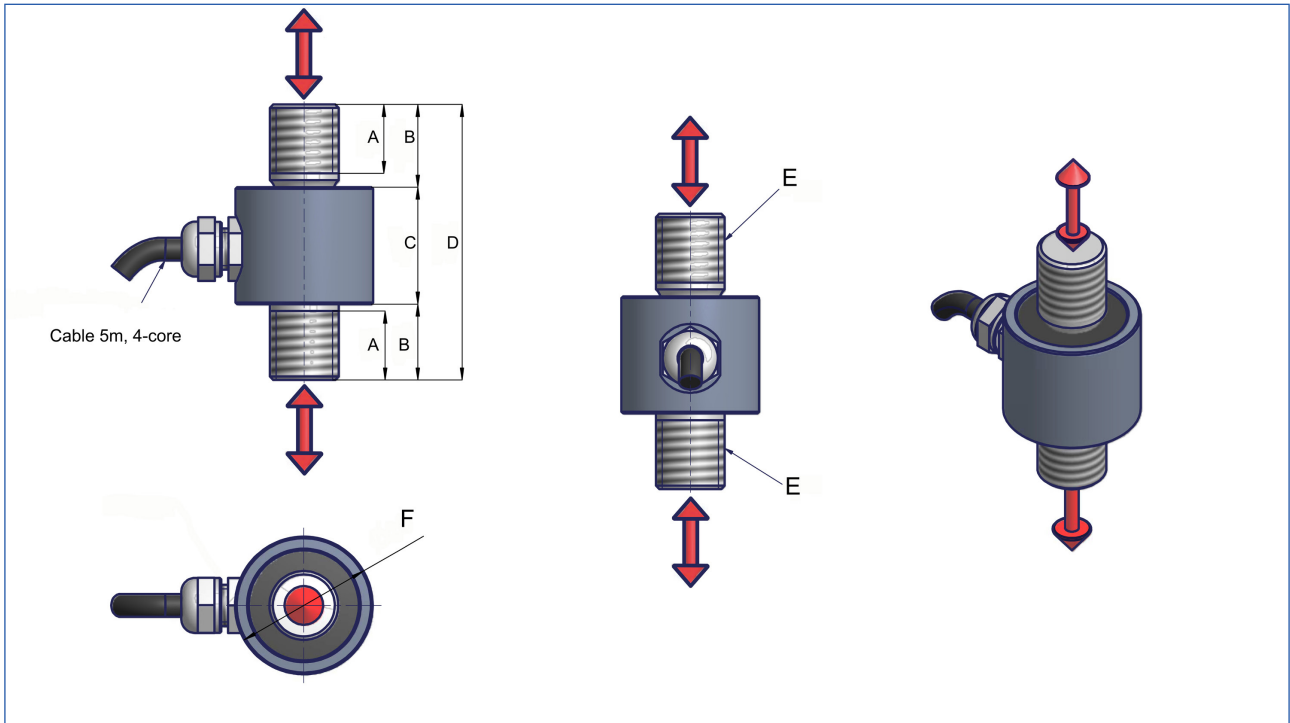

Dimensions in mm					
Model 304					
	1kN	5kN	10kN	20kN	50kN
	2kN				
A	8	8	10	12	16
B	8	9	12	13	17
C	19	17	17	19	16
D	35	35	40	45	50
E	M8 x1,25	M8 x1,25	M10 x1,5	M12 x1,75	M16 x2
F	Ø18	Ø20	Ø20	Ø24	Ø32

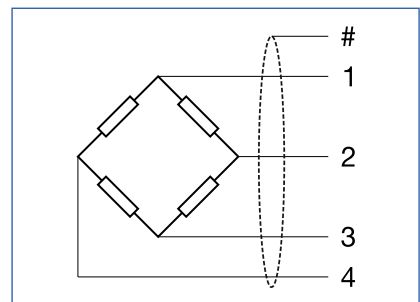

Connection Drawing		
1	blue	Excitation +
2	white	Output +
3	black	Excitation -
4	red	Output -
#		Shield

Advice for tensile force measurements:
 For force transmission please pay attention to an installation that is free of lateral forces, if necessary use rotating intermediate parts or joint heads with shackles.
 For safety reasons you should use arresting cables, straps or chains when other mechanical protection is not existing.