

Electrical Force Transducers – Model 302



- Capacities: 1kN bis 10kN
- For compression
- Stainless steel
- Small dimensions
- Sensitivity: 2mV/V
- High accuracy
- For dynamic applications
- Optional: TEDS module ¹⁾

The electrical force transducers of the model series 302 are space-saving and due to their low construction height they also fit into small installation spaces. They are made of stainless steel and are exclusively applicable for compressive forces. The installation of a TEDS module inside the plug is possible on demand so that the prerequisites for an automatic sensor recognition are set.

| Model 302 | | | |
|---|-------------|-----------|------------------|
| >> Technical data according to VDI / VDE directive 2638 | | | |
| | Symbol | Unit | Standard |
| Zero signal when removed | S_0 | mV/V | 0,02 |
| Rated characteristic value | C_{nom} | mV/V | 2 |
| Relative error of characteristic value | d_c | % | $\leq \pm 0,1$ |
| Relative linearity error | d_{lin} | % | $\leq \pm 0,06$ |
| Relative repeatability error in unchanged mounting position | b_{rg} | % | $\leq \pm 0,02$ |
| Combined error | F_{comb} | % | $\leq \pm 0,1$ |
| Reference temperature | T_{ref} | °C | 21 |
| Rated temperature range | $B_{T,nom}$ | °C | -10...+40 |
| Operating temperature range | $B_{T,G}$ | °C | -15...+60 |
| Storage temperature range | $B_{T,S}$ | °C | -20...+70 |
| Relative creep after 30 min | $K_{0,5}$ | % | $\leq \pm 0,06$ |
| Relative creep after 8 h | K_8 | % | $\leq \pm 0,018$ |
| Temperature effect on characteristic value per 10K | TK_C | % | $\leq \pm 0,05$ |
| Temperature effect on zero signal per 10K | TK_0 | % | $\leq \pm 0,05$ |
| Input resistance | R_e | Ω | 750 ± 25 |
| Output resistance | R_a | Ω | 700 ± 2 |
| Insulation resistance | R_{is} | $G\Omega$ | > 5 |
| Max. excitation voltage | U | V | 15 |
| Rated range of excitation voltage | $B_{U,nom}$ | V | 5...10 |
| Limit force | F_L | % | ≤ 150 |
| Breaking force | F_B | % | ≥ 300 |
| Max. permissible dynamic load ²⁾ | L_{dy} | % | ≤ 75 |
| Degree of protection acc. to DIN 60529 | | | IP67 |

¹⁾ TEDS = Transducer Electronic Data Sheet acc. to IEEE 1451.4

²⁾ Oscillation amplitude acc. to DIN 50100



Electrical Force Transducers – Model 302

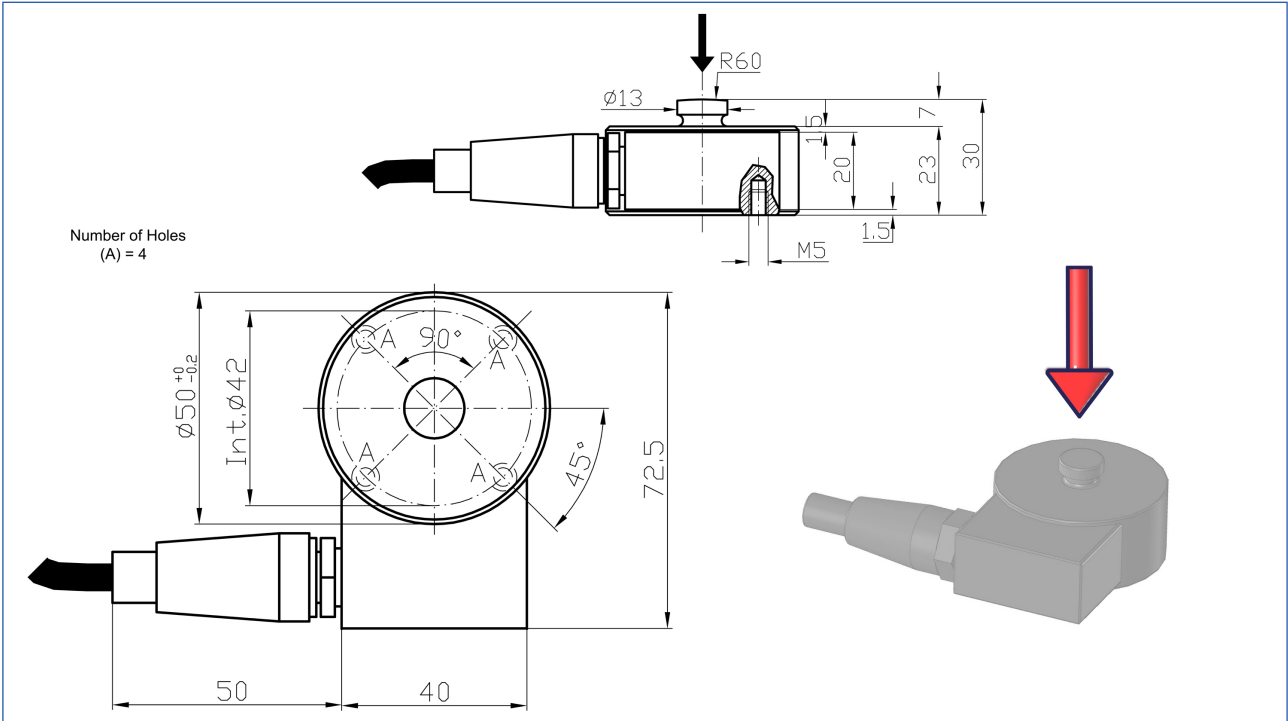

Number of Holes
(A) = 4

| Capacities | | | | |
|------------|-----|-----|-----|------|
| Model 302 | 1kN | 2kN | 5kN | 10kN |

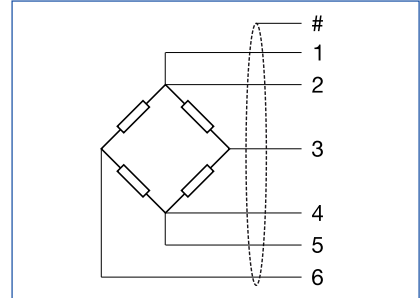

| Connection Drawing | | |
|--------------------|--------|--------------|
| 1 | white | Sense + |
| 2 | red | Excitation + |
| 3 | yellow | Output + |
| 4 | blue | Excitation - |
| 5 | black | Sense - |
| 6 | green | Output - |
| # | | Shield |